

40cm Petrol Scarifier







IMPORTANT! PLEASE READ THESE INSTRUCTIONS CAREFULLY. NOTE ALL SAFETY INSTRUCTIONS AND WARNINGS. USE THE PRODUCT CORRECTLY AND WITH CARE FOR THE PURPOSE FOR WHICH IT IS INTENDED. FAILURE TO FOLLOW THESE INSTRUCTIONS MAY CAUSE DAMAGE TO PROPERTY AND/OR PERSONAL INJURY.

PLEASE KEEP THESE INSTRUCTIONS SAFE AND AVAILABLE FOR FUTURE REFERENCE.

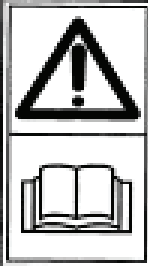
KNOW YOUR PETROL SCARIFIERS

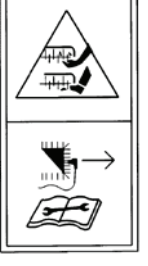
Read this manual carefully, observing the recommended safety instructions before, during and after using your scarifier. Following these simple instructions will also maintain your scarifier in good working order. Familiarize yourself with the controls on your scarifier before attempting to operate it, but above all, be sure you know how to stop your scarifier in an emergency.

SYMBOLS MARKED ON THE PRODUCT

	<p>Read this instruction book carefully before using the scarifier and keep it in a safe place for future reference.</p>
	<p>Keep bystanders away.</p>
 	<p>Sharp tines - Beware of cutting fingers or toes.</p> <p>Remove spark plug lead before maintenance.</p>
	<p>Wear eye protection.</p>
	<p>Wear ear protection.</p>
	<p>Carbon monoxide(CO) danger</p>

GENERAL SAFETY INFORMATION

IMPORTANT

READ CAREFULLY BEFORE USE

KEEP FOR FUTURE REFERENCE

Read the operating instructions carefully. Be familiar with the controls and the proper use of the machine. Local regulations can restrict the age of the operator.

Training

1) Read the instructions carefully. Be familiar with the controls and the proper use of the machine.

Preparation

1) Never allow people unfamiliar with these instructions or children to use the machine.

2) Never operate the machine while people, especially children or pets are nearby.

3) Operators should take care to prevent accidents to themselves or other people and damage to property.

4) Wear ear protection and safety glasses at all times while operating the machine.

5) While operating the machine, always wear substantial footwear and long trousers. Do not operate the machine when barefoot or wearing open sandals.

6) Thoroughly inspect the area where the machine is to be used and remove all stones, sticks, wires, bones and other foreign objects.

7) **WARNING** – Petrol is highly flammable.

8) Store fuel in containers specifically designed for this purpose.

9) Refuel outdoors only and do not smoke while refuelling.

10) Add fuel before starting the engine. Never remove the cap of the fuel tank or add petrol while the engine is running or when the engine is hot.

11) If petrol is spilled, do not attempt to start the engine but move the machine away from the area of spillage and avoid creating any source of ignition until petrol vapours have dissipated.

12) Store All fuel tanks safely with container caps securely tightened.

13) Replace faulty silencers.

14) Before using, always visually inspect to see that the tines and bolts are not worn or damaged. Replace worn or damaged tines and bolts in sets to preserve balance.

15) For rear discharge appliances with exposed rear rollers, when used without a catcher, full eye protection shall be worn.

Operation

- 1) Operate the machine only in daylight or in good artificial light.
- 2) Avoid operating the machine in wet grass or take additional precautions to avoid slipping.
- 3) Always be sure of your footing on slopes.
- 4) Walk, never run.
- 5) Always work across the face of slopes, never up and down.
- 6) Exercise extreme caution when changing direction on slopes.
- 7) Do not operate the machine on steep slopes.
- 8) Use extreme caution when reversing or pulling the machine towards you.
- 9) Stop the tines if the machine has to be tilted for transportation. Do not operate the tines when crossing surfaces other than grass and when transporting the machine to and from the working area.
- 10) Never operate the machine with defective guards or without safety devices, for example deflectors and/or catchers, in place.
- 11) Do not change the engine governor settings or over-speed the engine.
- 12) Disengage all tine and drive clutches before starting the engine.
- 13) Start the engine carefully according to instructions and with feet well away from the tine(s).
- 14) Do not tilt the machine when starting the engine, except if the machine has to be tilted for starting. In this case, do not tilt it more than absolutely necessary and lift only the part which is away from the operator.
- 15) Do not put hands or feet near or under rotating parts. Keep clear of the discharge opening at all times.
- 16) Never pick up or carry a machine while the engine is running;
- 17) Avoid operating the machine in bad weather conditions especially when there is a risk of lightning.
- 18) Stop the engine, disconnect the spark plug wire and for battery start machines remove the ignition key:
 - 18.1) Before clearing blockages or unclogging chute.
 - 18.2) Before checking, cleaning or working on the machine.
 - 18.3) After striking a foreign object. Inspect the machine for damage and make repairs before restarting and operating the machine.
 - 18.4) If the machine starts to vibrate abnormally (check immediately).
- 19) Stop the engine, disconnect the spark plug wire and for battery start machines remove the ignition key:
 - 19.1) whenever you leave the machine.
 - 19.2) before refuelling.
 - 19.3) reduce the throttle setting during engine shut down and if the engine is provided with a shut-off valve, turn the fuel off at the conclusion of aerating or scarifying.

Maintenance and storage

- 1) Keep all nuts, bolts and screws tight to be sure the machine is in a safe working condition;
- 2) Never store the machine with petrol in the tank inside a building where fumes can reach an open flame or spark.
- 3) Allow the engine to cool before storing in any enclosure.
- 4) To reduce the fire hazard, keep the engine, silencer, battery compartment and petrol storage area free of grass, thatch, moss, leaves or excessive grease.
- 5) Check the catcher frequently for wear or deterioration.
- 6) Examine the machine regularly and replace worn or damaged parts for safety.
- 7) If the fuel tank has to be drained, this should be done outdoors. The drained fuel should be stored in a container specifically designed for fuel storage or it should be disposed of carefully.

LAYOUT AND ITEMS SUPPLIED

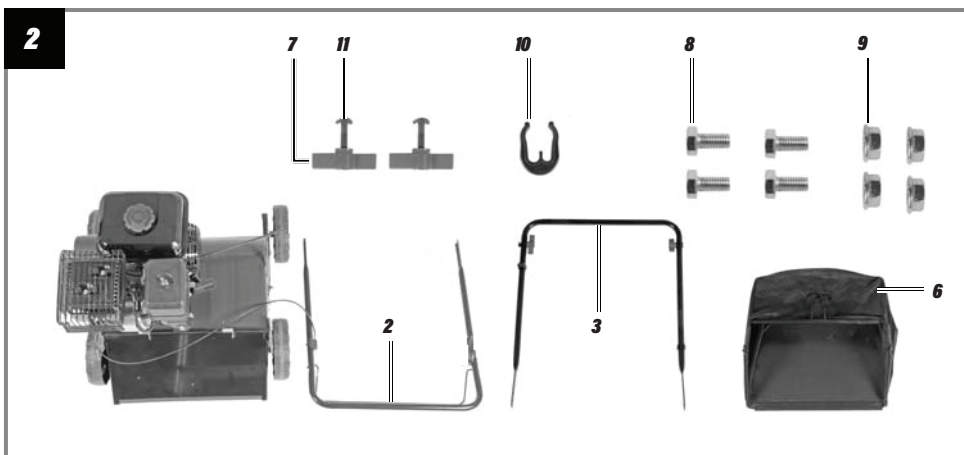
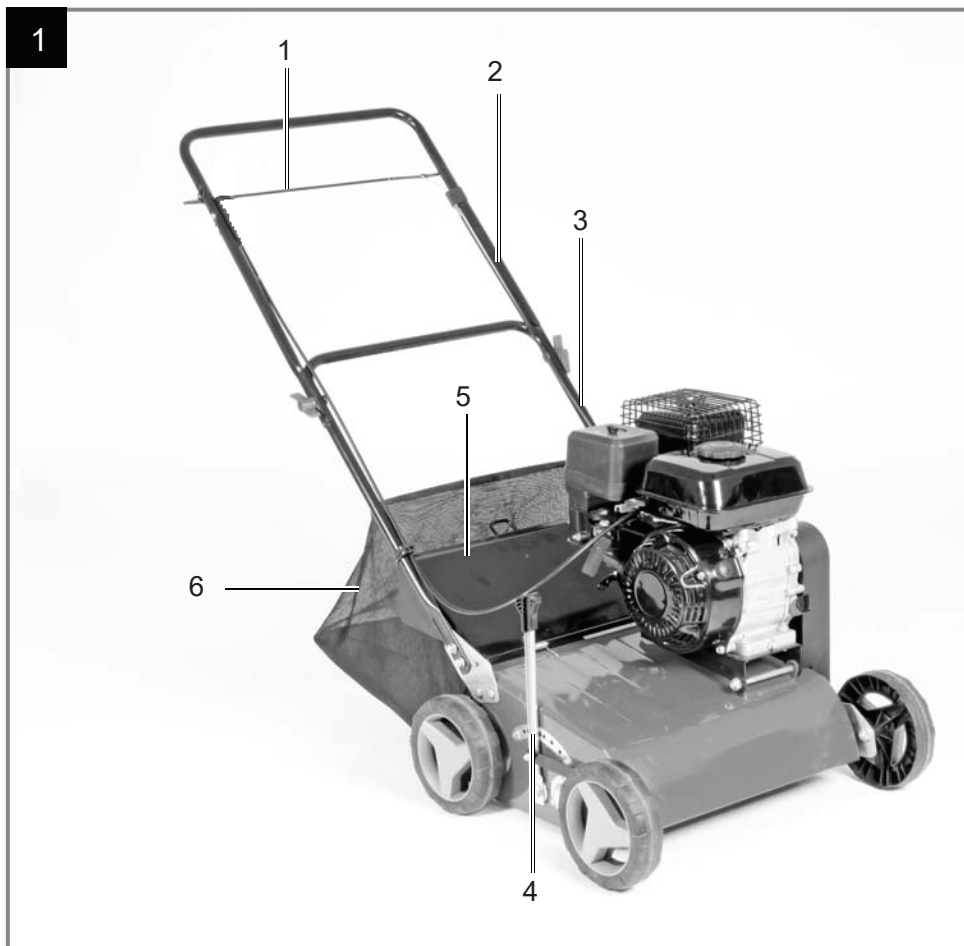

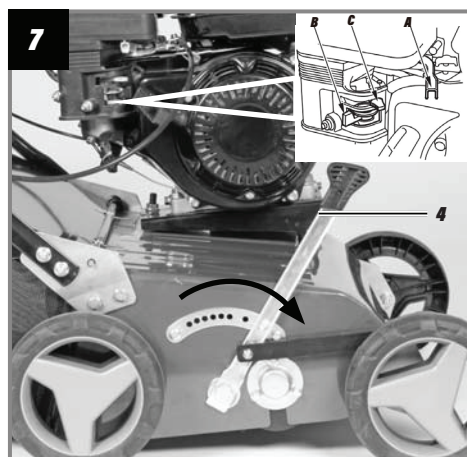
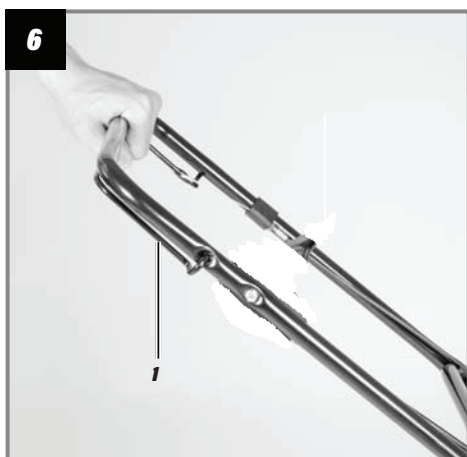
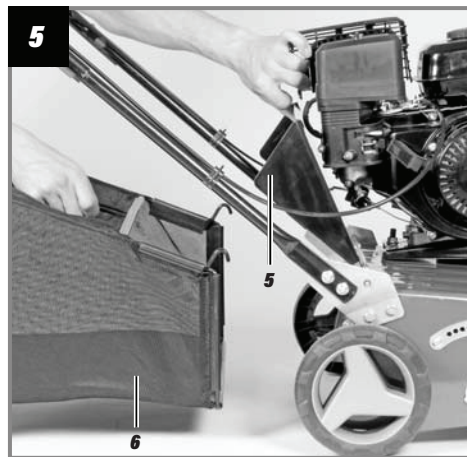
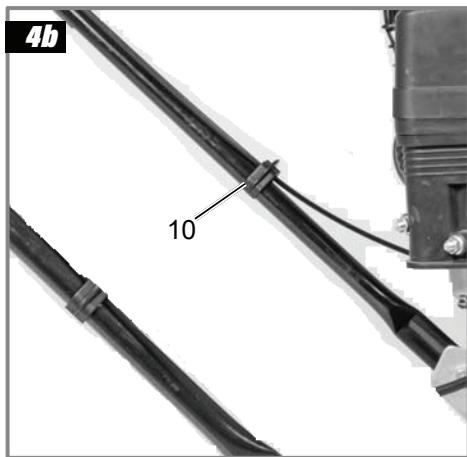
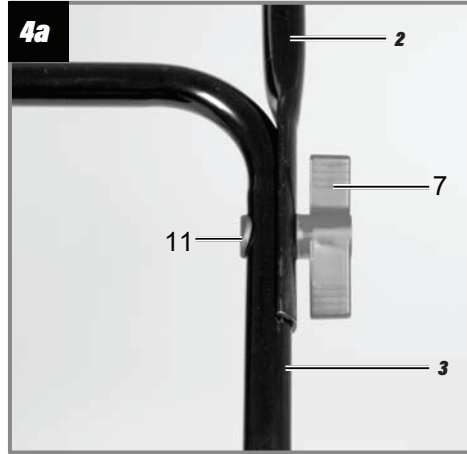
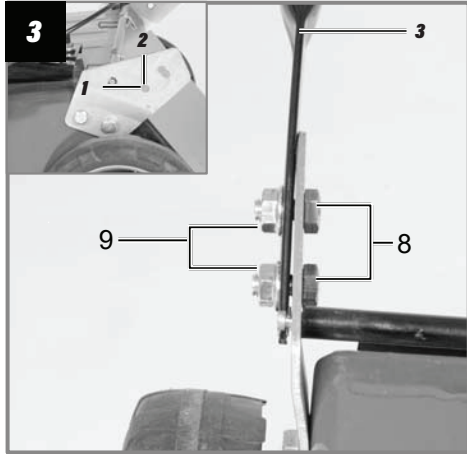

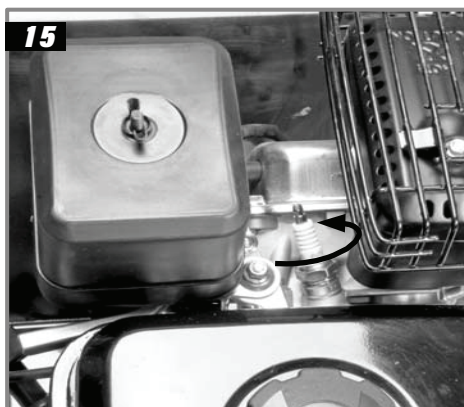
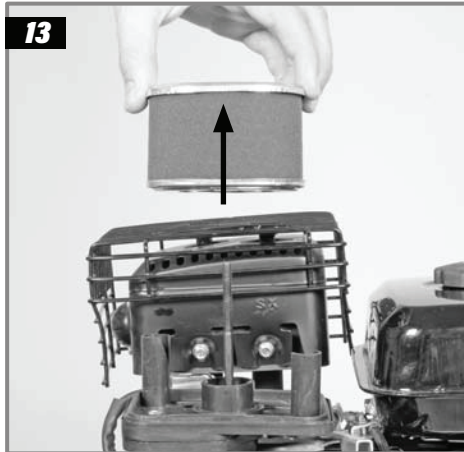
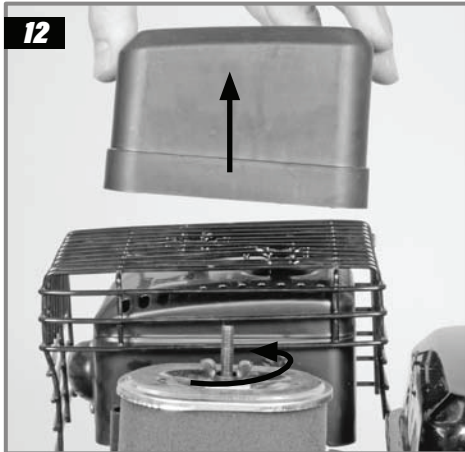
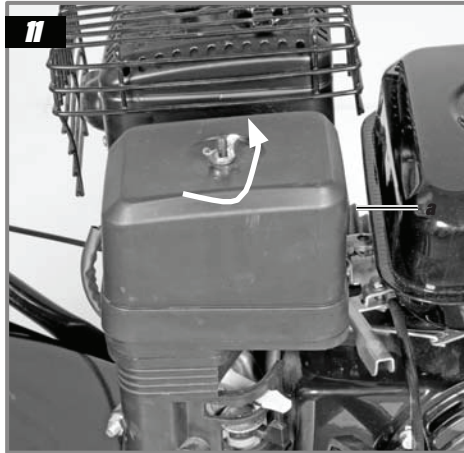
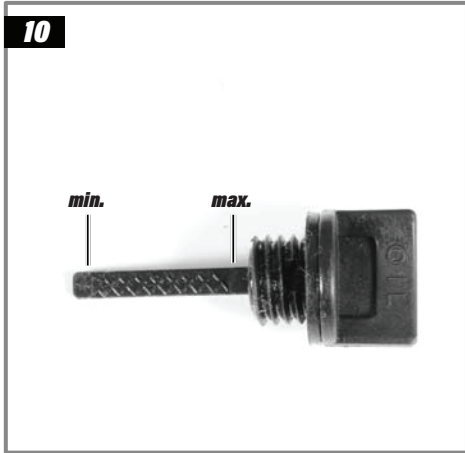
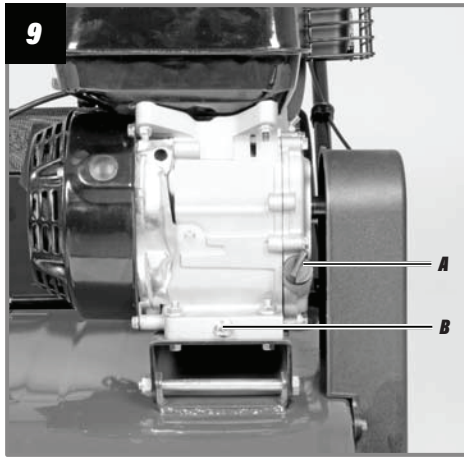
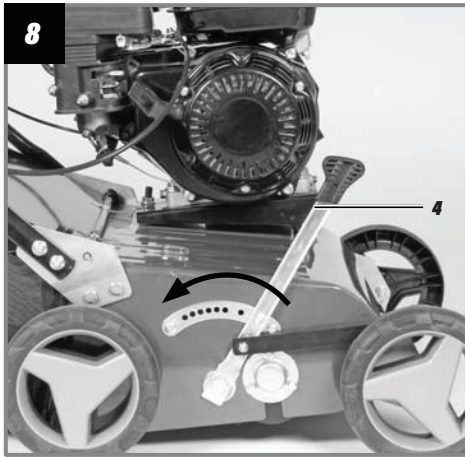

LAYOUT AND ITEMS SUPPLIED

Layout (Fig. 1/2)

1. Engine start/stop lever – engine brake
2. Top push bar
3. Bottom push bar
4. Scarifying depth
5. Ejector flap
6. Grass basket
7. (2x) Fastening nuts for top push bar
8. (4x) Fastening screws for bottom push bar
9. (4x) Fastening nuts for bottom push bar
10. Cable securing clips
11. (2x) Fastening screws for top push bar

Unpacking

Open the packaging and take out the equipment with care.

Remove the packaging material and any packaging and/or transportation braces (if applicable).

Check to see if all items are supplied.

Inspect the equipment and accessories for transport damage.

If possible, please keep the packaging until the end of the guarantee period.

DANGER! The equipment and packaging material are not toys. Do not let children play with plastic bags, foils or small parts. There is a danger of swallowing or suffocating!

Proper Use

The equipment is designed for scarifying lawned areas. The scarifying process is designed for ripping moss and weeds complete with their roots out of the soil and for loosening the soil. As a result your lawn can absorb nutrients better and is cleaned. We recommend you scarify your lawn in the spring (April) and autumn (October).

IMPORTANT! Due to the high risk of bodily injury to the user, the equipment may not be used to grind up branch or hedge clippings. Moreover, the equipment may not be used as a power cultivator to level out high areas such as mole hills. For safety reasons, the equipment may not be used as a drive unit for other work tools or tool sets of any kind.

The equipment is to be used only for its prescribed purpose. Any other use is deemed to be a case of misuse. The user / operator and not the manufacturer will be liable for any damage or injuries of any kind caused as a result of this.

Please note that our equipment has not been designed for use in commercial, trade or industrial applications. Our warranty will be voided if the machine is used in commercial, trade or industrial businesses or for equivalent purposes.

TECHNICAL DATA

Engine type	1 cylinder, 4-stroke	Engine oil (L)	0.6
Displacement (cm ³)	212	Blades	18
Engine Power (kW)	4.3	Blade diameter (mm)	166
Engine rated speed (r/min)	3600	Depth setting (mm)	-15 +15
Working speed (r/min)	2800	Working width (mm)	400
Fuel type	Unleaded petrol	Tank capacity (L)	3.6
Sound pressure level at the operator position dB(A)	82	Weight (kg)	34±5
Measured uncertainty k dB(A)	2	Left hand vibration (m/s ₂)	35
A-weighted sound power level dB(A)	95	Right hand vibration (m/s ₂)	35
Measured uncertainty k dB(A)	2	Uncertainty k (m/s ₂)	0.5

Before starting the equipment

The equipment is delivered unassembled. The grass basket and the complete push bar must be assembled and mounted before using the equipment. Follow the operating instructions step- by-step and use the pictures provided as a visual guide to easily assemble the equipment.

Fitting the top push bar holder (Fig. 4a)

Position the upper push bar (Fig. 4a / Item 2) such that its holes line up with the holes of the lower bar. Screw the tubes together, using the screws (Fig. 4a / Item 12) and nuts (Fig. 4a / Item 8) supplied.

Use the supplied cable clips (Fig. 4b / Item 11) to secure the throttle cable and the engine Start / Stop cable to the lower push bar.

Fit the debris box (Fig. 5)

Lift the ejector flap (Fig. 5 / Item 5) with one hand and attach the debris box (Fig. 5/Item 6) to the handle from above using your other hand.

IMPORTANT: Before you attach the debris box you must ensure that the engine is switched off and the roller is not rotating.

OPERATION

IMPORTANT!

The engine does not come with oil in it. Therefore, be sure to add oil before starting the engine. The oil level in the engine must be checked each time before carrying out any work.

IMPORTANT!

When the engine brake lever is released, it must return to its initial position and the engine must stop. If this is not the case, do not use the equipment again.

Starting the equipment (Fig. 6 – 7)

In order to avoid any unintentional start-ups of the engine, it comes equipped with an engine brake (Fig. 6/Item 1) which must be pressed at all times whilst the device is in use, otherwise the engine will stop.

Open the fuel cock (Fig. 7 / Item B). Set the cock to "ON" for this purpose.

Set the choke lever (Fig. 7/Item C) to the "Choke" position.

Note: Normally the choke is not required to restart a warm engine.

Move the throttle lever (Fig. 7 / Item A) to the center position.

Press the engine brake lever (Fig. 6 / Item 1) and pull the starter cable (Fig. 7 / Item A) forcefully until the engine starts.

Allow the engine to warm up briefly and then set the choke lever (Fig. 7 / Item C) to the "RUN" Position.

The speed of the cutter unit can be controlled using the throttle lever (Fig. 7 / Item A) (tortoise = slow / rabbit = fast).

IMPORTANT!

Always pull the starter cable slowly until you feel the initial resistance before you then pull it quickly to start the engine. Do not allow the starter cable to whip back of its own accord.

IMPORTANT!

The scarifier roller begins to rotate as soon as the engine is started.

IMPORTANT!

Never open the ejector flap when the motor is running. A rotating cutting unit can cause injuries.

Always fasten the ejector flap carefully. The flap flips back to the "Closed" position by the tension springs!

Always ensure that a safe distance (provided by the long handles) is maintained between the user and the housing. Be especially careful when scarifying and changing direction on slopes and inclines. Maintain a solid footing and wear sturdy, non-slip footwear and long trousers.

Always scarify along the incline (not up and down).

For safety reasons, the scarifier may not be used to scarify inclines whose gradient exceeds 15 degrees.

Use special caution when backing up and pulling the scarifier (tripping hazard)!

Adjusting the working depth (Fig. 8)

To set the working depth, push the lever for setting the depth (Fig. 8 / Item 4) gently away from the device, set the required depth and then lock the lever back into position.

Stopping

When the work is finished, release the rotor engagement lever.

IMPORTANT!

For transport move the lever for setting the depth to the highest position.

Tips for proper working

It is recommended that you overlap scarifying paths a little. Try to scarify in straight lines for a nice, clean look. The aeration swaths should always overlap each other by a few centimeters in order to avoid bare strips.

As soon as grass clippings start to trail the scarifiers, it is time to empty the grass basket.

IMPORTANT!

Before taking off the grass basket, switch off the motor and wait until the roller has come to a complete stop.

To remove the grass basket, lift up the ejector flap with one hand, while unhooking the basket with the other.

How frequently you should scarify your lawn is determined primarily by the speed at which the grass grows and the hardness of the soil.

Keep the underside of the equipment clean and remove soil and grass build-up. Deposits make it more difficult to start the aerator and decrease the quality of the scarifying.

Always scarify along inclines (not up and down). Switch off the motor before doing any checks on the roller.

IMPORTANT!

The roller rotates for a few seconds after the motor is switched off. Never attempt to stop the roller. In the event that the rotating roller strikes an object, immediately switch off the equipment and wait for the roller to come to a complete stop. Then inspect the condition of the roller. Replace any parts that are damaged.

Cleaning, maintenance, storage, transport and ordering of spare parts**IMPORTANT!**

Never work on or touch conducting parts on the ignition unit with the engine running.

Always pull the spark plug boot from the spark plug before starting any work of care or maintenance. Never perform any work on the machine while it is running. Any work not described in these Operating Instructions must be performed by an authorised service workshop only.

Cleaning

The scarifier should be cleaned thoroughly every time after it has been used. This particularly applies to its underside and the blades. To do so tip the scarifier slightly on to its side and remove the dirt.

IMPORTANT!

Before you tip the equipment, the petrol tank must be emptied to prevent petrol leaking out. Ideally you should use a conventional petrol extraction pump for this purpose.

Servicing

Checking the oil level

Set the equipment down on a flat, level surface.

Unscrew the oil dipstick by turning it anti-clockwise. The oil level must be as shown in Figure 10.

IMPORTANT!

Never run the engine with no or too little oil. This can cause serious damage to the engine.

Changing the oil

- 1) Change the engine oil every year before the start of the season (in addition to the information in the petrol service manual) when the engine is warm.
- 2) Use only recommended engine oil.
- 3) Place a suitable oil drip tray beneath the oil drain screw.
- 4) Remove the oil filler screw (Fig. 9 / Item A).
- 5) Undo the oil drain screw (Fig. 9 / Item B) and drain the oil into a suitable container.
- 6) Close the drain screw again when all the used oil has been drained.
- 7) Pour engine oil into the equipment as shown in Figure 10.
- 8) Dispose of the used oil in accordance with applicable regulations.

Care and adjustment of the cables

Oil the cables at regular intervals and check that they move easily.

Servicing the air filter

Soiled air filters reduce the engine output by supplying too little air to the carburetor.

Regular checks are therefore essential. The air filter should be checked after every 50 hours of use and cleaned if necessary. If the air contains a lot of dust, the air filter should be checked more frequently.

- 1) Remove the air filter as shown in Fig. 11-13.
- 2) Clean the air filter only with compressed air or by tapping it.
- 3) Assemble in reverse order

IMPORTANT!

Never clean the air filter with petrol or inflammable solvents.

Servicing/Replacing the spark plug

Check the spark plug for dirt and grime after 10 hours of operation and if necessary clean it with a copper wire brush. Thereafter service the spark plug after every 50 hours of operation.

- 1) Pull off the spark plug boot (Fig. 14) with a twist.
- 2) Remove the spark plug using a spark plug wrench (Fig. 15).
- 3) Assemble in reverse order.

Preparing the equipment for storage

CAUTION!

Do not empty the petrol tank in enclosed areas, near fire or when smoking. Petrol fumes can cause explosions and fire.

- 1) Empty the petrol tank with a petrol suction pump.
- 2) Start the engine and let it run until any remaining petrol has been used up.
- 3) Change the oil at the end of every season. To do so, remove the used engine oil from a warm engine and refill with fresh oil.
- 4) Remove the spark plug from the cylinder head. Fill the cylinder with approx. 20 ml of oil from an oil can. Slowly pull back the starter handle, which will bathe the cylinder wall with oil. Screw the spark plug back in.
- 5) Clean the cooling fins of the cylinder and the housing.
- 6) Be sure to clean the entire machine to protect the paint.
- 7) Store the machine in a well-ventilated place.

Preparing the device for transport

- 1) Drain the petrol tank using a petrol extraction pump.
- 2) Always let the engine run until it has used up the remainder of petrol in the tank.
- 3) Empty the engine oil from the warm engine.
- 4) Remove the spark plug boot from the spark plug.
- 5) Clean the cooling fins of the cylinder and the housing.
- 6) Remove the push bars if necessary. Ensure that the cables are not kinked.

Ordering replacement parts

Please quote the following data when ordering replacement parts:

- 1) Type of machine
- 2) Article number of the machine
- 3) Identification number of the machine

TROUBLESHOOTING

Fault	Possible Causes	Remedy
The motor does not start	Engine brake lever not pressed Spark plug defective	Press the engine brake lever Replace spark plug Top up fuel
Engine does not run smoothly	Air filter dirty Spark plug worn Choke open	Clean the air filter Clean/Replace the spark plug Set choke lever to "Run" position
The equipment does not operate smoothly	Blades imbalanced	Have the blades replaced by a customer service workshop.
Motor is running, roller does not rotate	V-belt torn	Have the V-belt replaced by a customer service workshop.

EC DECLARATION OF CONFORMITY

1. Product model: SCA300
2. Name and address of the manufacturer or his authorised representative:



SGS Engineering (UK) Ltd
Unit 1 West Side Park, Raynesway, Derby, DE21 7AZ
Telephone: +44 (0)1332 576 850

3. This declaration of conformity is issued under the sole responsibility of the manufacturer.
4. Object of the declaration:

Equipment: 40cm Petrol Scarifier
Brand name: SGS

5. The object of the declaration described above is in conformity with the relevant statutory requirements:

Machinery Directive (2006/42/EC)
Electromagnetic Compatibility Directive (2014/30/EU)
Noise Emission Directive by equipment for use outdoors (2000/14/EC + 2005/88/EC)
Assessment Procedure: 2000/14/EC, amended by 2005/88/EC- Annex VI
- Measured Sound Power Level - LwA 95 dB(A)
- Guarantee Sound Power Level - LwA 98 dB(A)

6. References to the relevant designated standards used or references to the other technical specifications in relation to which conformity is declared:

EN ISO 5395-1:2013
EN ISO 5395-2:2013/A2:2017
EN ISO 14982:2009

7. The person authorized to compile the technical file:

Name: Neil Sansom
Address: SGS Engineering (UK) Ltd, Unit 1 West Side Park, Raynesway, Derby, DE21 7AZ

Signed for and on behalf of:

Authorised Representative

A handwritten signature in black ink, appearing to read 'Neil Sansom', written over a horizontal line.

Neil Sansom, CEO
Date: 10/09/2025





SGS-ENGINEERING.COM